

THIS DRAWING IS UNPUBLISHED. RELEASED FOR PUBLICATION  
 © COPYRIGHT - By - ALL RIGHTS RESERVED.

LOC	DIST	REVISIONS			
P	LTR	DESCRIPTION	DATE	DWN	APVD
AF	50	E	REVISED PER ECR-11-018063	26DEC11	KH PD

- 1 CONTINUOUS STRIP ON REELS.
- 2 ACCEPTS .032±.001 THICK MATING TAB
- 3 ACCEPTS #18-#14 AWG WIRE SIZE.
- 4 INSULATION RANGE TO BE .120-.170 DIA
- 5 FEED TO BE .840±.005.

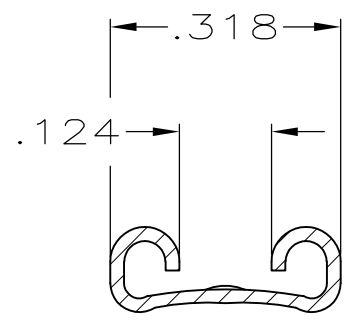
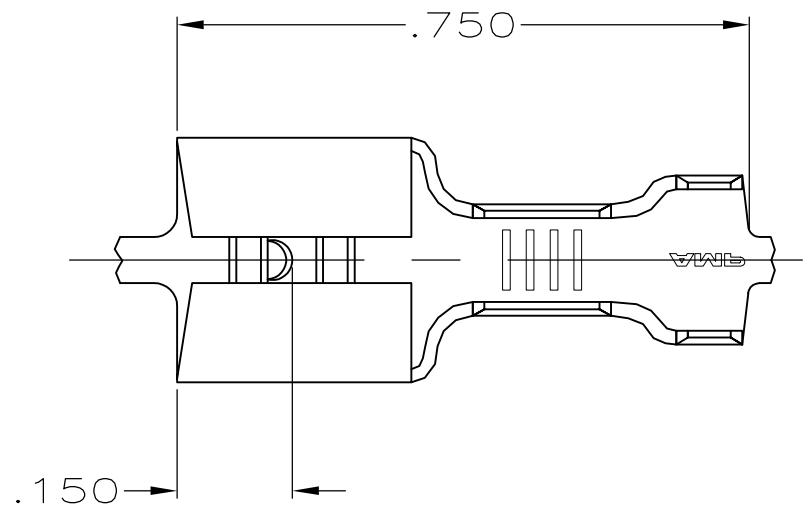

SECTION A-A

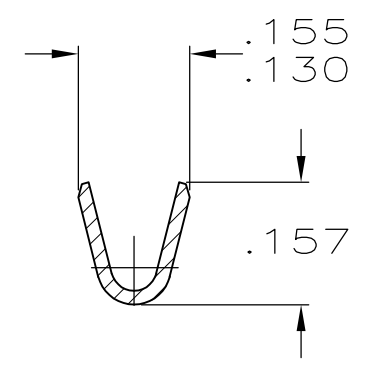
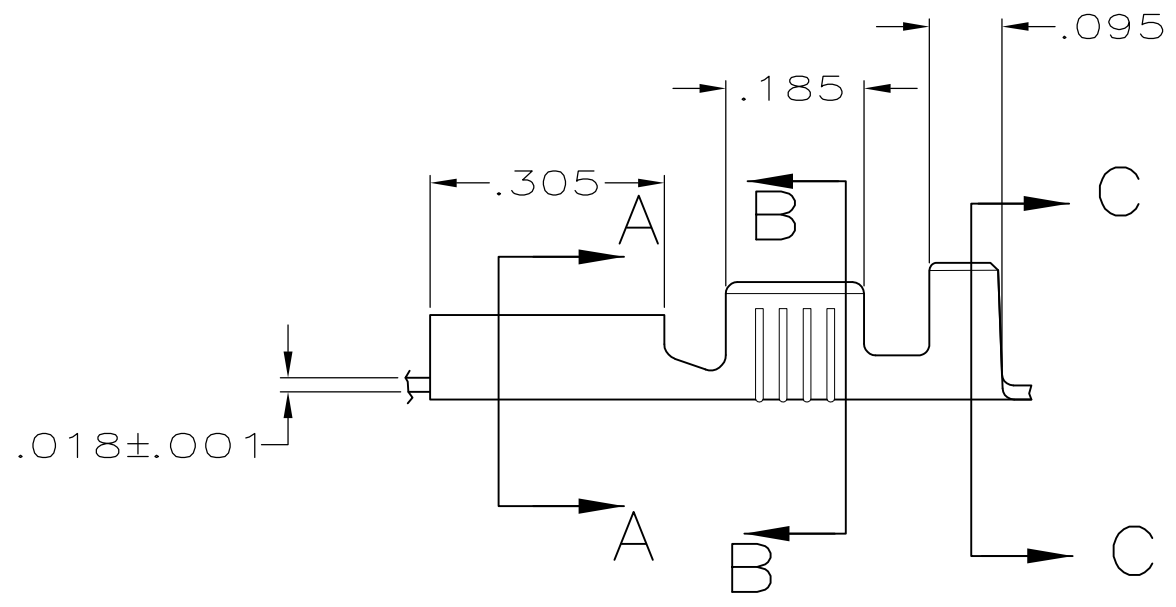

SECTION B-B

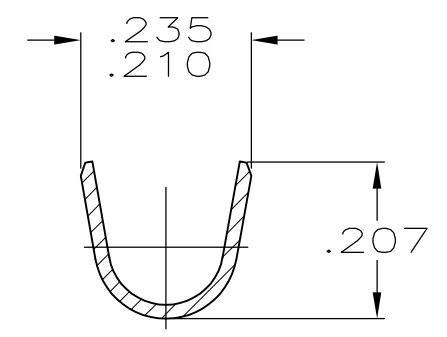

SECTION C-C

TIN	62500-2
-	62500-1
FINISH	PART NO

THIS DRAWING IS A CONTROLLED DOCUMENT.		DWN	JR RUTH	8/30/95	<b>STE</b> TE Connectivity		
DIMENSIONS: INCHES		CHK	MS FEHER	8/30/95			
TOLERANCES UNLESS OTHERWISE SPECIFIED:		APVD	J HUZVAR	8/30/95	NAME		
0 PLC ± -		PRODUCT SPEC		RECEPTACLE, FASTON, .250 SERIES			
1 PLC ± -		APPLICATION SPEC		SIZE	CAGE CODE	DRAWING NO	RESTRICTED TO
2 PLC ± -		MATERIAL		A300779		C-62500	-
3 PLC ± .015		FINISH		CUSTOMER DRAWING			SCALE
4 PLC ± -		MATERIAL		SCALE 4:1			SHEET
ANGLES ± -		MATERIAL		SCALE 4:1			SHEET 1 OF 1
FINISH		MATERIAL		SCALE 4:1			REV E